



For more Hi-Fi manuals and set-up information
please visit www.hifiengine.com

ONKYO SERVICE MANUAL

STEREO CASSETTE TAPE DECK MODEL TA-RW111



Black model

BMD, BMDN	120V AC, 60Hz
-----------	---------------

SAFETY-RELATED COMPONENT WARNING!!

COMPONENTS IDENTIFIED BY MARK Δ ON THE SCHEMATIC DIAGRAM AND IN THE PARTS LIST ARE CRITICAL FOR RISK OF FIRE AND ELECTRIC SHOCK. REPLACE THESE COMPONENTS WITH ONKYO PARTS WHOSE PART NUMBERS APPEAR AS SHOWN IN THIS MANUAL.

MAKE LEAKAGE-CURRENT OR RESISTANCE MEASUREMENTS TO DETERMINE THAT EXPOSED PARTS ARE ACCEPTABLY INSULATED FROM THE SUPPLY CIRCUIT BEFORE RETURNING THE APPLIANCE TO THE CUSTOMER.

SPECIFICATIONS

Track Format:	4-track, 2-channels
Erasing System:	AC erase
Tape Speed:	4.8 cm/sec. (1-7/8 i.p.s.) 9.6 cm/sec. (3-3/4 i.p.s.) (high speed dubbing)
Wow and Flutter:	0.08% (WRMS)
Frequency Response:	20 - 15,000 Hz (Normal) (30 - 14,000 Hz \pm 3 dB) 20 - 16,000Hz (High) (30 - 15,000Hz \pm 3 dB) 20 - 17,000Hz (Metal) (30 - 16,000Hz \pm 3 dB)
S/N Ratio:	Dolby NR off: 58dB (metal position tape) A noise reduction of 10dB above 5kHz and 5dB at 1kHz is possible with Dolby B NR. A noise reduction of 20dB at 5kHz is possible with Dolby C NR.
Input Jacks:	Line IN: 2 Input sensitivity: 80mV Input impedance: 50 kohms
Outputs:	Line OUT: 2 Standard output level: 500mV (0dB) Optimum load impedance: over 50 kohms
Motors:	DC servo motor \times 2
Heads:	REC/PB: 1 PB: 1 ERASE: 1
Power Consumption:	17 watts
Dimensions:	455 (W) \times 120 (H) \times 305 (D)mm (17-15/16" \times 4-3/4" \times 12")
Mass:	5.2 kg. (11.5 lbs.)

Specifications and external appearance are subject to change without notice because of product improvements.

ONKYO[®]

AUDIO COMPONENTS

BLOCK DIAGRAM

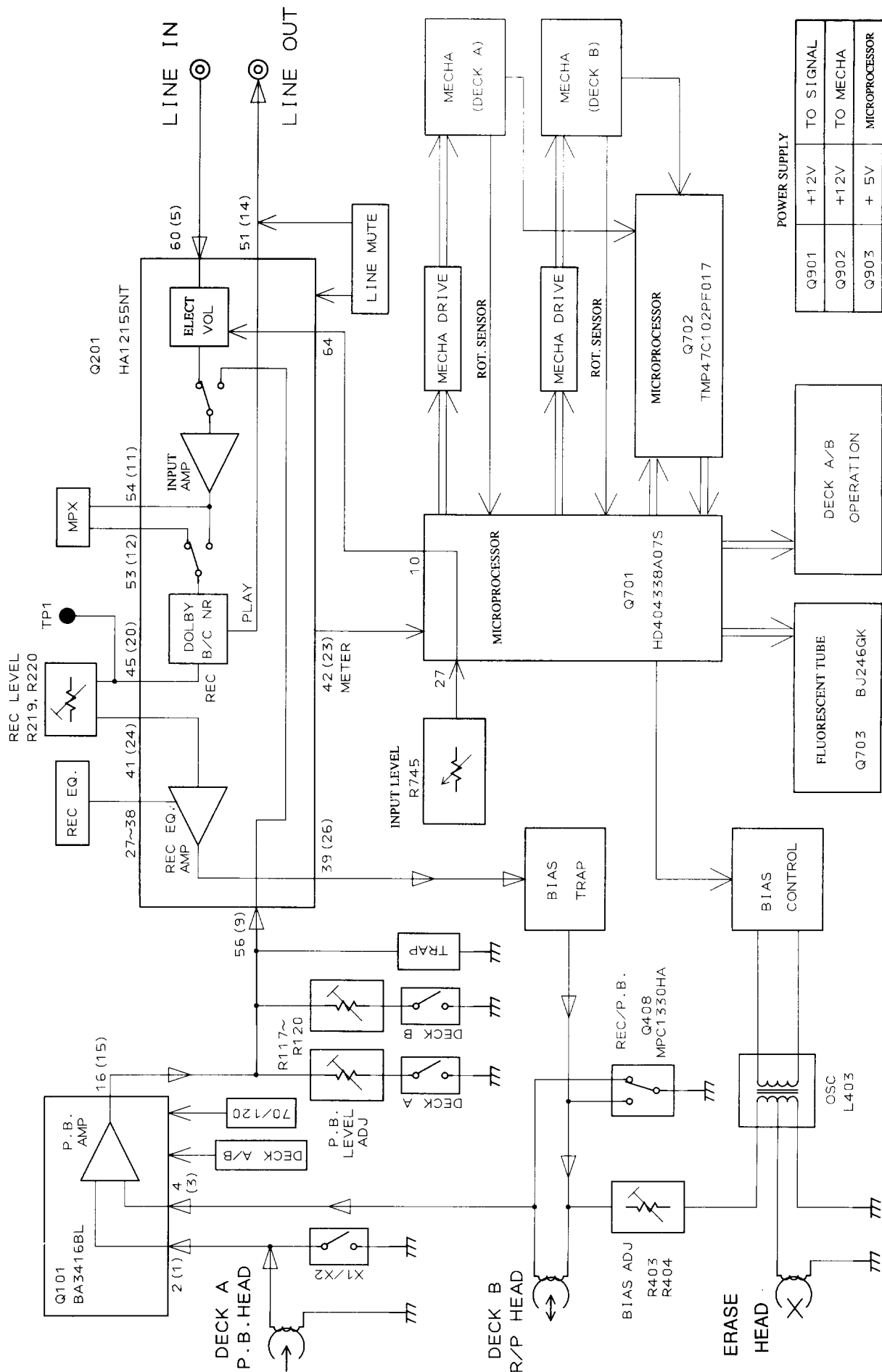

IC BLOCK DIAGRAMS

HA12155NT (DOLBY NR)

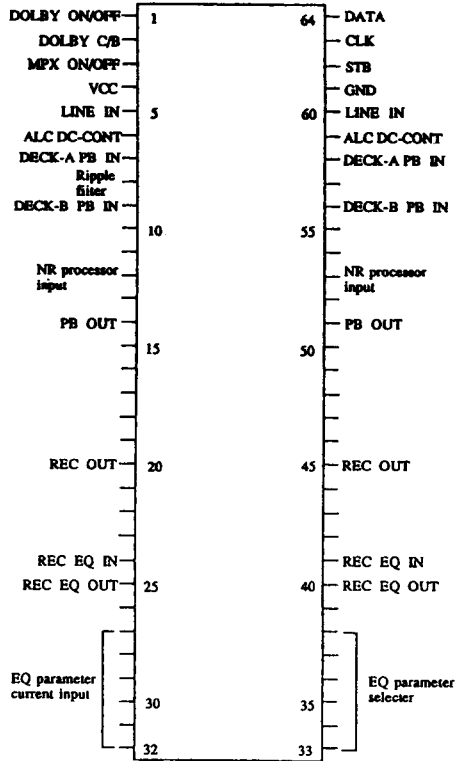

μPC1330HA (REC/PB SW)

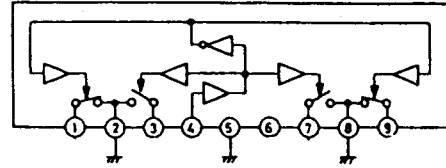

μPC1330HA

Pin No.	Function
1, 9	PB signal
2	GND
3, 7	REC signal
4	REC/PB SW control
5	GND
6	+B
8	GND

BA3416BL (Dual Playback Preampfier)

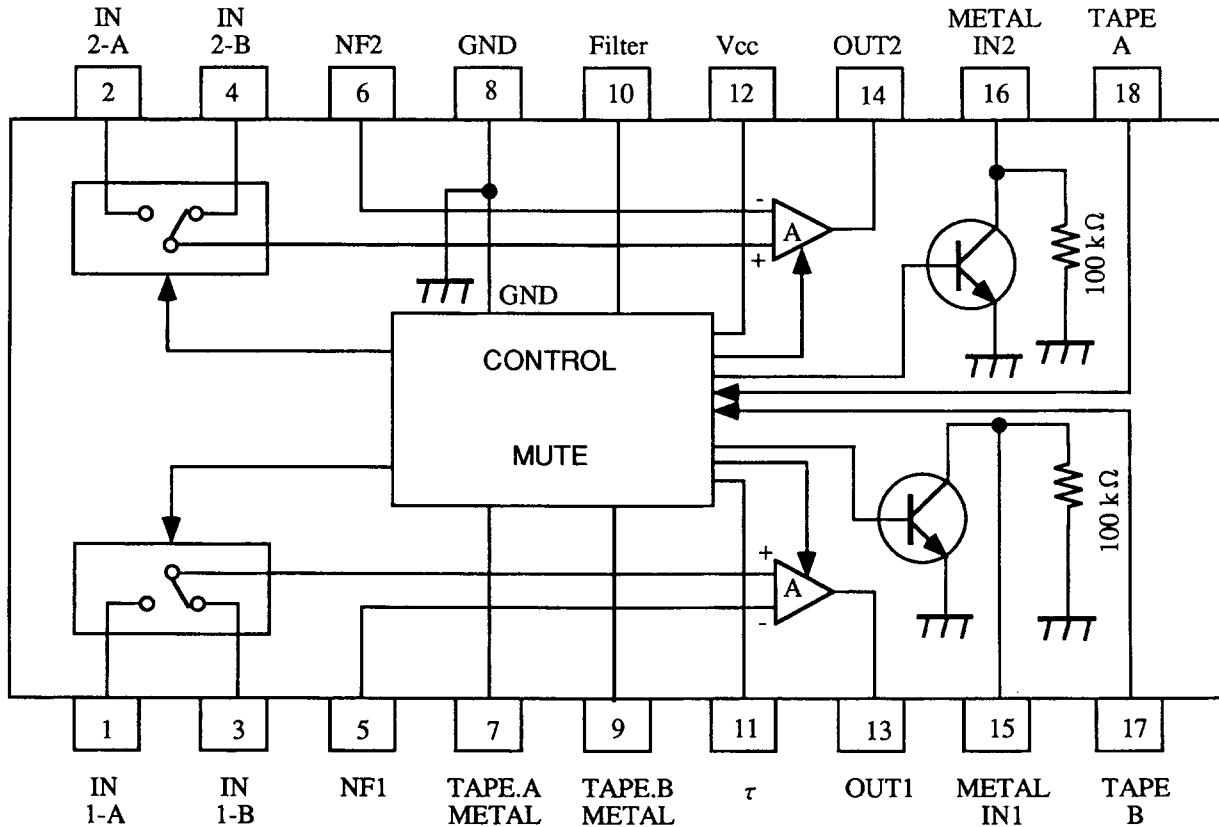

CHASSIS-EXPLODED VIEW

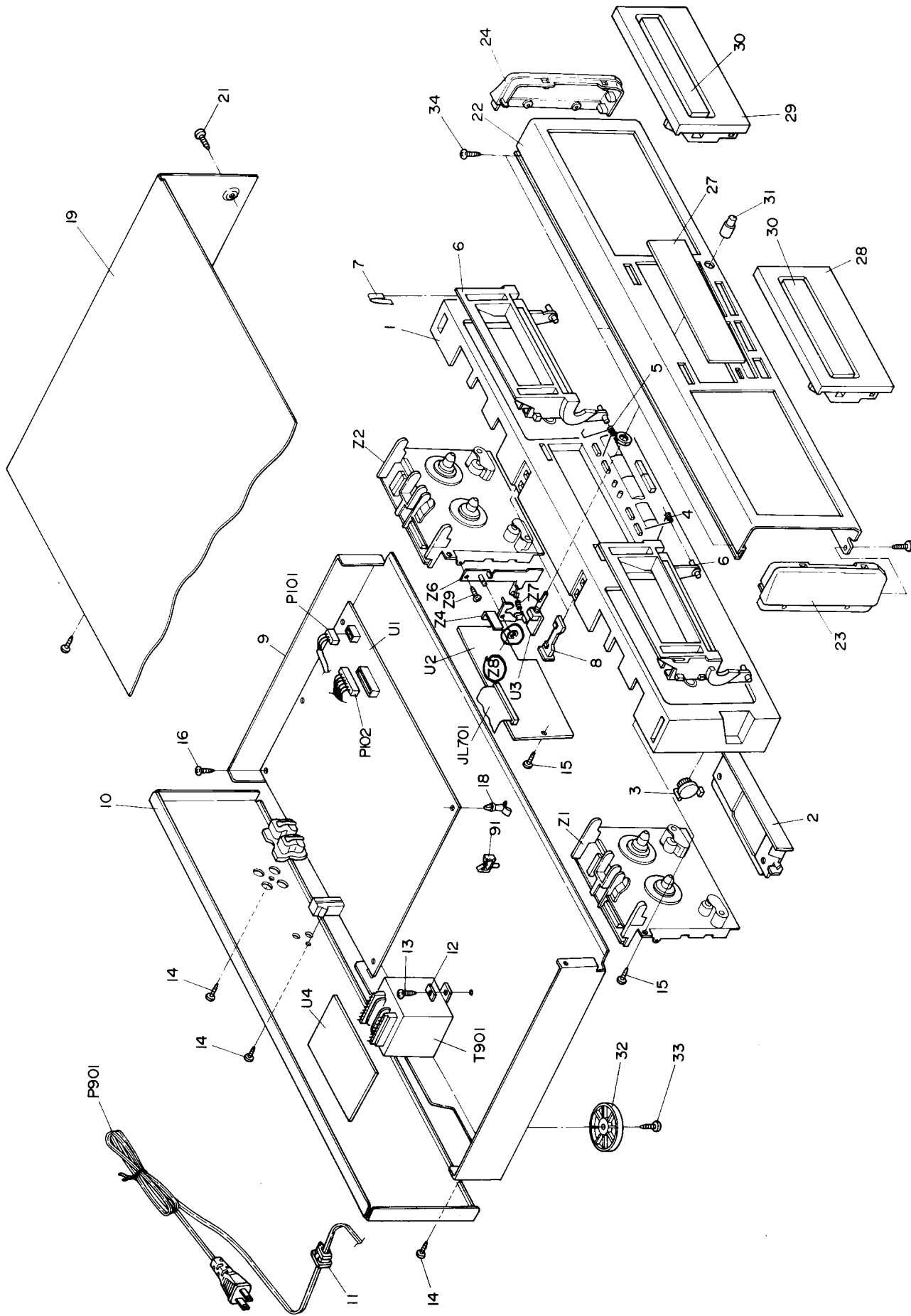

PARTS LIST

REF. NO.	PART NO.	DESCRIPTION	REF. NO.	PART NO.	DESCRIPTION
1	27110796Y	Front bracket	29	27301853-1Y	Cassette lid B
2	27262443	Plate T-1	30	28400625	Window
3	28400282	Damper	31	28324338	Knob, volume
4	27180476A	Spring B	32	271175292	Leg
5	27180477A	Spring A	33	838130088	3TTB+8B, Self-tapping screw
6	27301792AY	Cassette frame	34	833430080	3TTP+8P(BC), Self-tapping screw
7	27180272A	Spring	91	27300833	WS-2NS, Clamp
8	28324943Y	Knob, eject	JL701	2047292512Y	NCFC7-292512, Flexible flat cord
9	27100280AY	Chassis	P101	2009990312Y	NSAS-6P0446, Socket
10	27122007Y	Rear panel	P102	2009990313Y	NSAS-14P0447, Socket
11	27300750	△ Cord bushing	P901	253192HIT	△ AS-UC-6 #18, Power supply cord
12	870065	△ Flat washer	T901	2301008Y	△ NPT-1206D, Power transformer
13	830440089	4TTC+8C(BC), Self-tapping screw	U1	IN211576-3Y	NAAR-4976-3, Main circuit pc board ass'y
14	838130088	3TTB+8B, Self-tapping screw	U2	IN211577-3Y	NADIS-4977-3, Display circuit pc board ass'y
15	833430080	3TTP+8P(BC), Self-tapping screw	U3	IN211578-3Y	NAAF-4978-3, Input volume pc board ass'y
16	838130088	3TTB+8B, Self-tapping screw	U4	IN211579-3Y	NAPS-4979-3, Power supply pc board ass'y
17	835430068	3TTF+6B(BC), Self-tapping screw	Z1	244186	NDM-177, Deck mechanism A
18	27190480-1Y	PCB-8L, Holder	Z2	244187AY	NDM-178, Deck mechanism B
19	28184479AY	Top cover	Z3	24603402Y	Lever L, eject
21	838430088	3TTB+8B(BC), Self-tapping screw	Z4	24603404Y	Lever R, eject
22	IN211121Y	Front panel ass'y	Z5	24611591Y	Retainer L
23	28125248-6Y	End cap L	Z6	24611593Y	Retainer R
24	28125249-6Y	End cap R	Z7	24605798Y	Spring
25	28198802Y	Facet	Z8	8930301S	Ring E
26	28135199	Badge	Z9	833126047	2.6TTP+4S, Self-tapping screw
27	28191676Y	Clear plate			
28	27301853Y	Cassette lid A			

NOTE: THE COMPONENTS IDENTIFIED BY MARK **△** ARE CRITICAL FOR RISK OF FIRE AND ELECTRIC SHOCK. REPLACE ONLY WITH PART NUMBER SPECIFIED.

ADJUSTMENT PROCEDURES

PRECAUTIONS

1. Before adjustment, clean the following parts with an alcohol moistend swab.

- * record/playback head
- * erase head
- * pinch roller
- * capstan

2. Do not use magnetized screwdriver for adjustments.

3. Demagnetize record/playback head with a liead demagnetizer.

TEST EQUIPMENT/TOOLS REQUIRED:

- Audio oscillator
- Digital frequency counter
- Oscilloscope
- Attenuator
- AC voltmeter
- Non-magnetic screwdriver
- Test tapes
 - TCC-153 :10kHz, -15dB
 - MTT-111 :3kHz, -10dB
 - MTT-150 :Dolby level calibration
400Hz, tone 200nWb/m

Tape speed adjustment

Connect the digital frequency counter to the line output terminal.

Load the test tape MTT-111 into the cassette holder.

Connect the test point TP-2 to the ground to be the unit to adjustment mode.

Press the forward play button. (The unit becomes the high speed.)

Adjust the trim resistors R802(Deck A) and R817(Deck B) so that the frequency counter reading becomes 6000Hz to 6020Hz.

Press the forward play button. (The unit becomes the normal speed.)

Adjust the trim resistors R803(Deck A) and R818(Deck B) so that the frequency counter reading becomes 3000Hz to 3010Hz.

Item	Connection of instrument	Line input	Test tape	Mode	Output indicator	Adjustment point	Adjust	Remarks
1	Head azimuth		TCC-153	PB	AC voltmeter Oscilloscope	Head azimuth acrew	Maximum and same phase at channels L and R	fig-1
2	Playback level		MTT-150	PB	AC voltmeter	DECK A R117 (ch. L) R118 (ch. R) DECK B R119 (ch. L) R120 (ch. R)	300mV	
3	Bias frequency		METAL TAPE XS-C90	REC	Frequency counter	L403	85kHz±2kHz	
4	Bias current	fig-2	1kHz, -23dB and 12kHz, -23dB	UD-1 C-90	REC/PB	AC voltmeter R403 (ch. L) R404 (ch. R)	Same level at 1kHz and 12kHz	Repeat the recording and play back until the 1kHz and 12kHz playback signals are same level.
5	Record level	fig-2	1kHz	UD-1 C-90	REC	AC voltmeter Attenuator or AF OSC output	350mV	
					REC/PB	AC voltmeter R219 (ch. L) R220 (ch. R)	Same level at REC/PB	

Blank tape NORMALUD-1 C-90
 HIGHXL-II C-90
 METAL.....XS C-60

PLAY torque.....30~70g/cm
 FF. REW torque80~180g/cm
 Back tention6~12g/cm

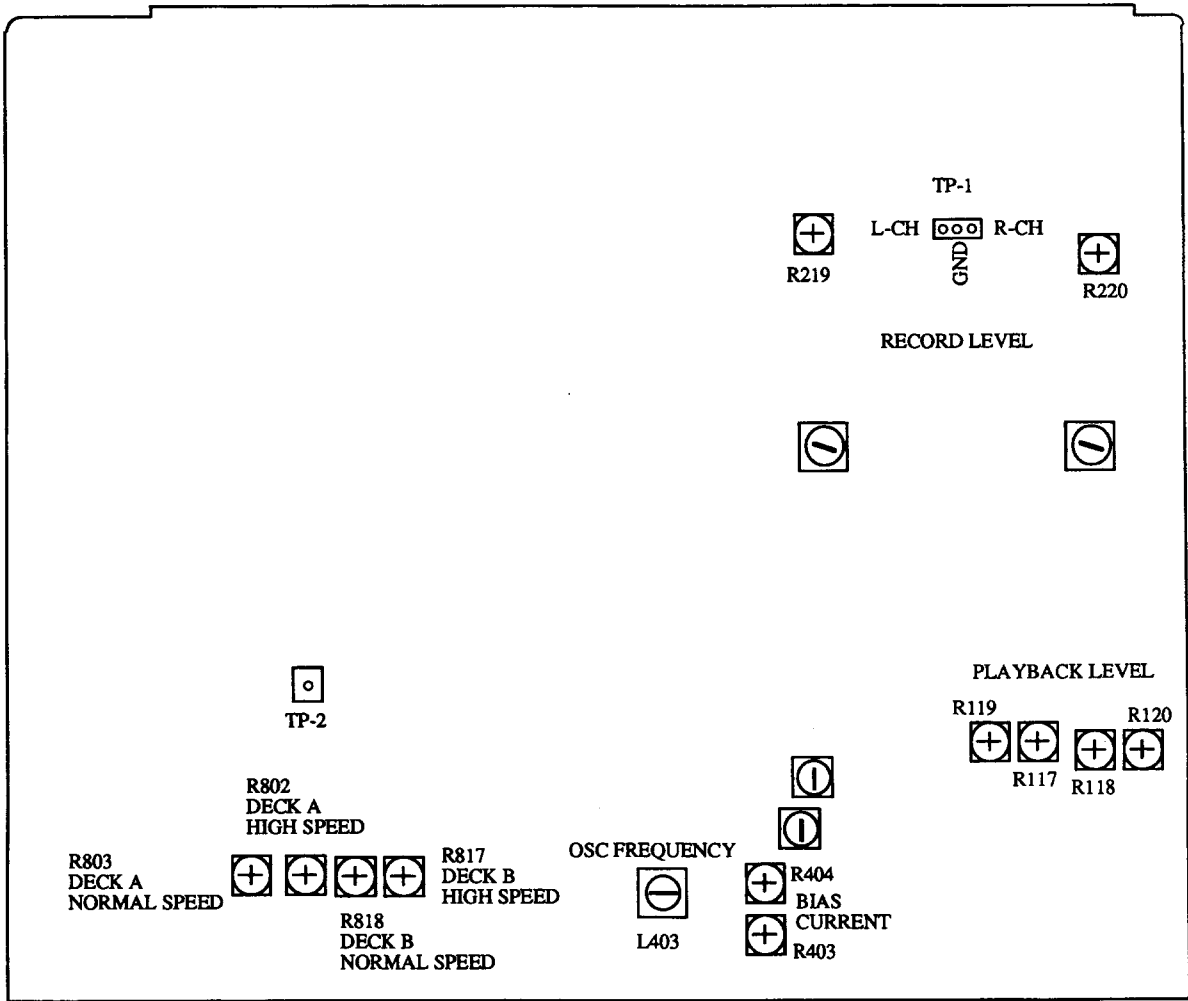

Adjustment point

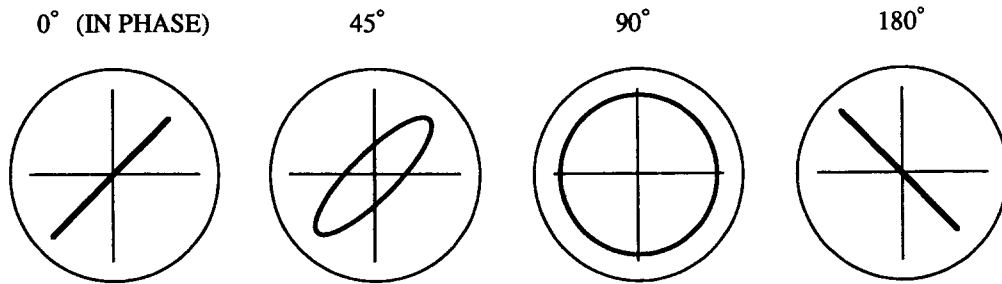

Confirming phase relationship

Fig. 1

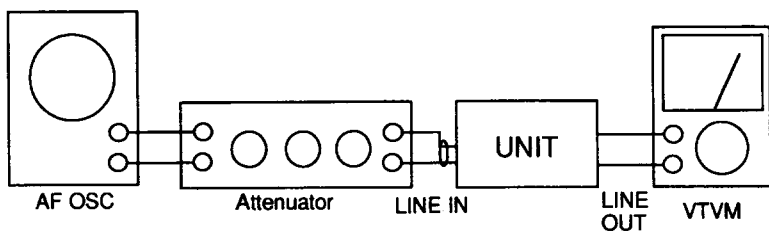

Fig. 2

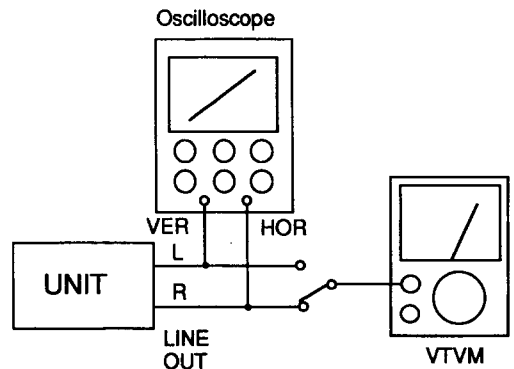
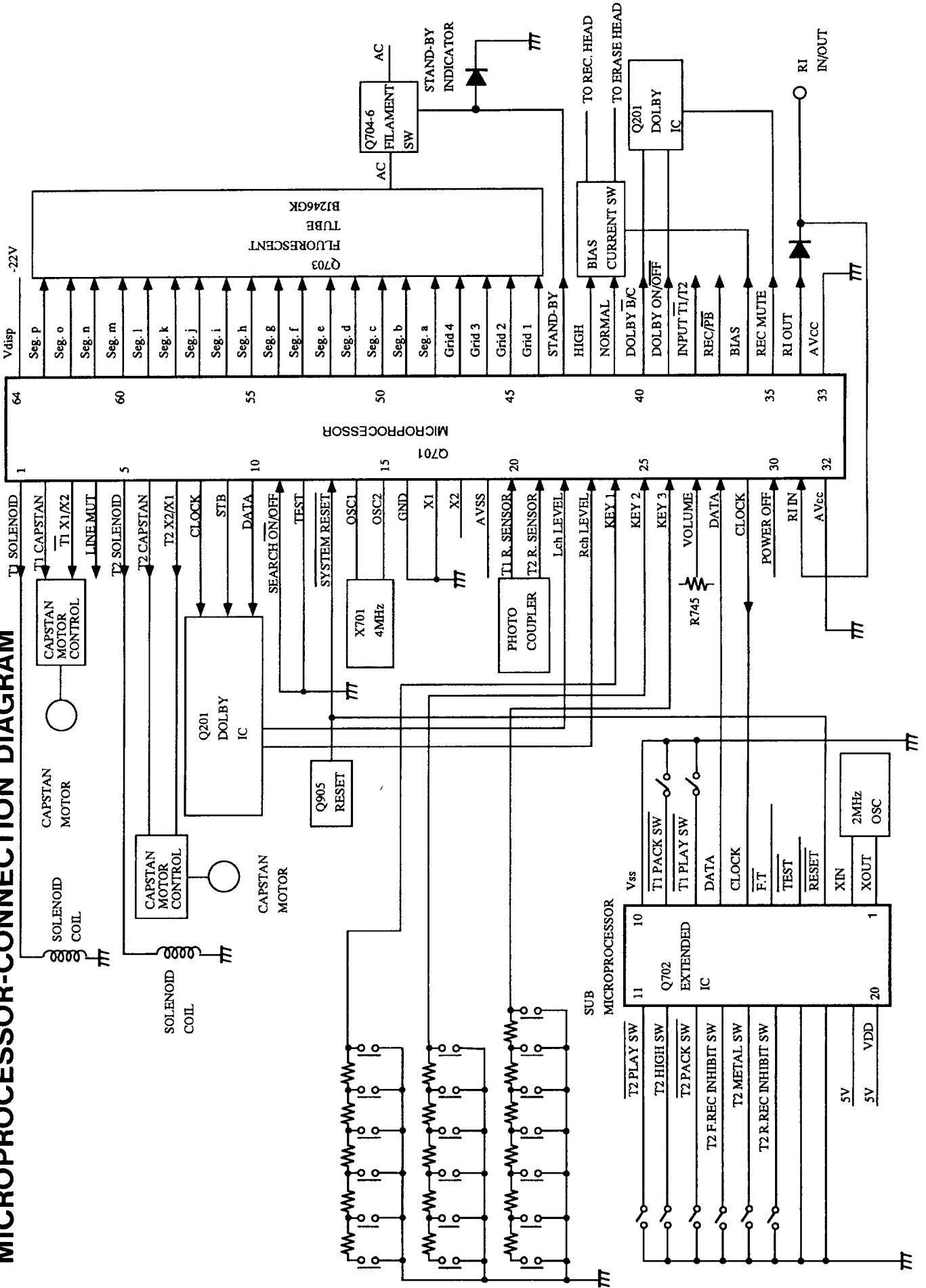

Fig. 3

MICROPROCESSOR-CONNECTION DIAGRAM



Pin No.	Function	Description	Remarks
1	T1 SOLENOID	Solenoid control output terminal	H
2	T1 CAPSTAN	Capstan motor control output terminal	H
3	T1 X1/X2	Capstan motor rotation control output terminal	H:Normal speed L: Double speed
4	LINE MUTE	Muting control output terminal	H
5	T2 SOLENOID	Solenoid control output terminal	H
6	T2 CAPSTAN	Capstan motor control output terminal	H
7	T2 X1/X2	Capstan motor rotation control output terminal	H:Normal speed L: Double speed
8	CLOCK		Clock output
9	STB	Serial transfer data output terminals with Doably IC	Strobe output
10	DATA		Data output
11	SEARCH ON/OFF	Initializing terminal of skip operation	L
12	TEST	Test terminal	Connect to 5V.
13	RESET	System reset terminal	L
14	OSC1	Clock input/output terminal to internal oscillator	
15	OSC2	Connect the 4 MHz ceramic resonator.	
16	GND	Ground terminal	
17	X1	Clock input/output terminals for resonator for timer	
18	X2	Not used.	
19	AVss	Power source terminal for A/D converter	Connect the ground.
20	T1 R. SENSOR	Signal input terminal from rotation sensor	
21	T2 R. SENSOR	Signal input terminal from rotation sensor	
22	L ch LEVEL	A/D input terminal for level input	
23	R ch LEVEL	Use the skip and indicator of level meter	
24	KEY 1		
25	KEY 2	Operation key connection terminals	
26	KEY 3		
27	VOLUME	A/D input terminal for volume position detection	
28	DATA	Transfer terminal with input extended microprocessor	Data input
29	CLOCK		Clock output
30	POWER OFF	Power stoppage detection input terminal	H
31	RI IN	System code input terminal	
32	AVcc	Power source terminal for A/D converter	
33	Vcc	Power source terminal	
34	RI OUT	System code output terminal	H
35	REC MUTE	Recording muting control output terminal	H
36	BIAS	Bias control output terminal	H
37	REC/PB	Recording/playback head selection terminal	
38	INPUT T1/T2	Playback equalizer selection terminal	
39	DOLBY ON/OFF	Dolby mode selection terminal	
40	DOLBY B/C	Refer table 1.	
41	NORMAL	Playback equalizer and bias selector terminal	
42	HIGH	Refer table 2.	
43	STAND-BY LED	Stand-by indicator and filament control output terminal	H
44~47	Grid 4~Grid 1	Grid output terminals	H
48~63	Seg. a~Seg. p	Segment output terminals	H
64	Vdisp	Pull-down resistor connection terminals	

DOLBY ON/OFF	DOLBY B/C	DOLBY MODE
L	L	DOLBY OFF
L	H	DOLBY OFF
H	L	DOLBY B
H	H	DOLBY C

Table 1

TAPE	NORMAL	HIGH
NORMAL	H	L
HIGH	L	H
METAL	L	L

Table 2

SUB MICROPROCESSOR

Pin No.	Function	Description
1	XOUT	Connect the 2 MHz ceramic resonator.
2	XIN	
3	RESET	Reset input
4	TEST	Test mode setting input of mechanism
5	FT	Setting input of adjustment
6	CLOCK	Clock input
7	DATA	Data output
8	T1 PLAY SW	Play switch input
9	T1 PACK SW	Switch input for detection of tape loading
10	Vss	Ground terminal
11	T2 PLAY SW	Play switch input
12	T2 HIGH SW	Switch input for detection of type of cassette tape
13	T2 PACK SW	Switch input for detection of tape loading
14	T2 F.REC INH SW	Recording prevention detection switch input of forward direction
15	T2 METAL SW	Switch input for detection of type of cassette tape
16	T2 R.REC INH SW	Recording prevention detection switch input of reverse direction
17	NC	--
18	NC	--

SCHEMATIC DIAGRAM

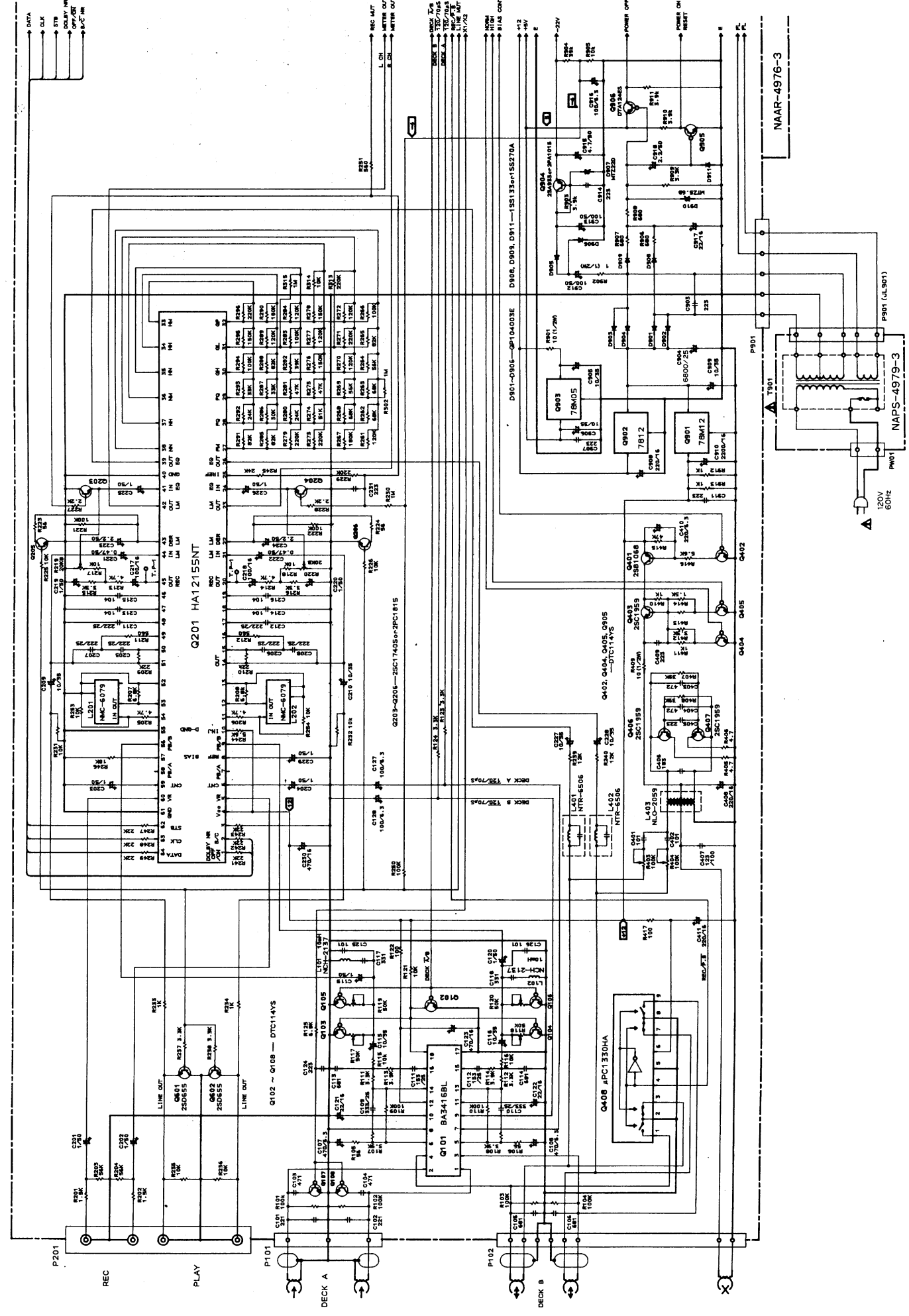

SCHEMATIC DIAGRAM

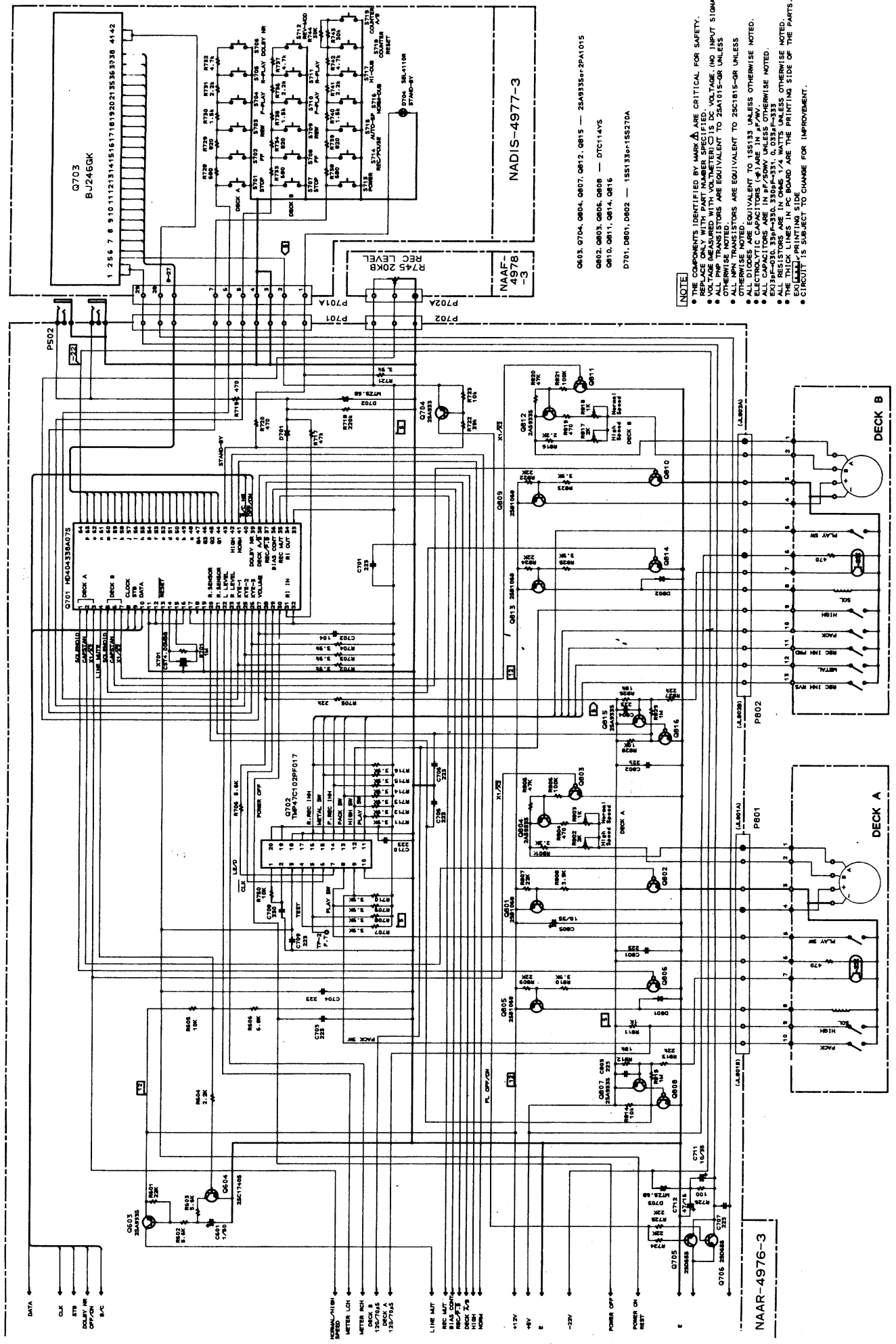

NOTE

- THE COMPONENTS IDENTIFIED BY MARK Δ ARE CRITICAL. FOR SAFETY, REPLACE ONLY WITH PART NUMBER SPECIFIED.
- VOLTAGE MEASURED WITH VOLTMETER C.I.S DC VOLTAGE (NO INPUT SIGNAL) UNLESS OTHERWISE NOTED.
- ALL MPN TRANSISTORS ARE EQUIVALENT TO 2SC1615-OR UNLESS OTHERWISE NOTED.
- ALL DIODES ARE EQUIVALENT TO 1SS133 UNLESS OTHERWISE NOTED.
- ELECTROLYTIC CAPACITORS (⊖) ARE IN μF/WV. ALL CAPACITORS ARE IN PF/50V UNLESS OTHERWISE NOTED.
- ALL RESISTORS ARE IN OHMS 1/4 WATTS UNLESS OTHERWISE NOTED.
- THE THICK LINES IN PC BOARD ARE THE PRINTING SIDE OF THE PARTS.
- CIRCUIT IS SUBJECT TO CHANGE FOR IMPROVEMENT.

0603, 0704, 0804, 0807, 0812, 0815 — 25A9335p-2PA1015
 0802, 0803, 0805, 0808 — DTCT14YS
 0810, 0811, 0814, 0816
 D701, D801, D802 — 1SS133p-1SS270A

NAAR-4976-3

NADIS-4977-3

PRINTED CIRCUIT BOARD-PARTS LIST

MAIN CIRCUIT PC BOARD (NAAR-4976-3)

CIRCUIT NO.	PART NO.	DESCRIPTION	CIRCUIT NO.	PART NO.	DESCRIPTION
	ICs			Coils	
Q101	22240767	BA3416BL	L101,L102	231089	NCH-2137
Q201	22240544	HA12155NT	L201,L202	233407	NMC-6079
Q408	22240147	μ PC1330HA	L401,L402	231165	NTR-6506
Q701	22240765	HD404388A-07S	L403	231215	NLO-2059
Q702	22240766	TMP47C102P-F017		Resonator	
Q901	222780125	78M12	X701	3010150	CST4.00MGW,Ceramic
Q902	222780120	7812		Capacitors	
Q903	222780055	78M05	C107,C108	354722219	220 μ F,6.3V,Elect.
	Transistors		C115,C116	354761009	10 μ F,35V,Elect.
Q102-Q108	221281	DTC114YS	C119,C120	354780109	1 μ F,50V,Elect.
Q203-Q206	2213285,	2SC1740S-S,	C121,C917	354742209	22 μ F,16V,Elect.
	2213284 or	2SC1740S-R or	C122	354761009	10 μ F,35V,Elect.
	2214915	2PC1815-GR	C123,C230	354744719	470 μ F,16V,Elect.
Q401,Q801	2212853 or	2SB1068-K or	C127,C128	354721019	100 μ F,6.3V,Elect.
Q805	2212855	2SB1068-U	C201-C204	354780109	1 μ F,50V,Elect.
Q402	221281	DTC114YS	C209,C210	354761009	10 μ F,35V,Elect.
Q403	2211544	2SC1959-Y	C213-C216	374721044	0.1 μ F \pm 5%,50V,Plastic
Q404,Q405	221281	DTC114YS	C217,C218	354741019	100 μ F,16V,Elect.
Q406,Q407	2211544	2SC1959-Y	C219,C220	354780109	1 μ F,50V,Elect.
Q601,Q602	2211705 or	2SD655-E or	C221,C222	354784799	0.47 μ F,50V,Elect.
Q705,Q706	2211706	2SD655-F	C223,C224	354780229	2.2 μ F,50V,Elect.
Q603,Q704	2213355,	2SA933S-S,	C225,C226	354780109	1 μ F,50V,Elect.
Q804,Q807	2213354 or	2SA933S-R or	C227,C228	354761009	10 μ F,35V,Elect.
Q812,Q815	2214905	2PA1015-GR	C229,C601	354780109	1 μ F,50V,Elect.
Q604	2213285	2SC1740S-S	C403,C404	374724724	4700pF \pm 5%,50V,Plastic
Q802,Q803	221281	DTC114YS	C405	374722234	0.022 μ F \pm 5%,50V,Plastic
Q806,Q808	221281	DTC114YS	C406	374721834	0.018 μ F \pm 5%,50V,Plastic
Q809,Q813	2212853 or	2SB1068-K or	C407	370131234	0.012 μ F \pm 5%,100V,Plastic
	2212855	2SB1068-U	C408,C411	354742219	220 μ F,16V,Elect.
Q810,Q811	221281	DTC114YS	C410	354722219	220 μ F,6.3V,Elect.
Q814,Q816	221281	DTC114YS	C702	374721044	0.1 μ F \pm 5%,50V,Plastic
Q904	2213355,	2SA933S-S,	C711,C805	354761009	10 μ F,35V,Elect.
	2213354 or	2SA933S-R or	C712	354744709	47 μ F,16V,Elect.
	2214905	2PA1015-GR	C903,C911	374722734	0.027 μ F \pm 5%,50V,Plastic
Q905	221281	DTC114YS	C904	3504210S	6800 μ F,25V,Elect.
Q906	2212600	DTA124ES	C905,C906	354761009	10 μ F,35V,Elect.
	Diodes		C908	354742219	220 μ F,16V,Elect.
D701	223163 or	1SS133 or	C909	354761009	10 μ F,35V,Elect.
D801,D802	223205	1SS270A	C910	393342227	2200 μ F,16V,Elect.
D702,D703	224450562	MTZ5.6B	C912,C913	354781019	100 μ F,50V,Elect.
D901-D906	22380035	GP104003E	C915	354780479	4.7 μ F,50V,Elect.
D907	224452204	MTZ22D	C916	354721019	100 μ F,6.3V,Elect.
D908,D909	223163 or	1SS133 or	C918	354780229	2.2 μ F,50V,Elect.
D911	223205	1SS270A			
D910	224450562	MTZ5.6B			

CIRCUIT NO.	PART NO.	DESCRIPTION
Resistors		
R117-R120	5210265	N06HR50KBC,Trim
R219,R220	5210263	N06HR20KBC,Trim
R403,R404	5210266	N06HR100KBC,Trim
R409,R901	443521004	10 Ω ,1/2W,Metal oxide
R802,R817	5210259	N06HR2KBC,Trim
R803,R818	5210258	N06HR1KBC,Trim
R902	453530104	1 Ω ,1/2W,Metal
Plugs		
P101,TP1	25055133	NPLG-3P117
P102	25055138	NPLG-8P122
Terminals		
P201	25045329	NPJ-4PDBL183,Output
P502	25045330	NPJ-2PDBL184,RI
Socket		
P701	25050861	NSCT-29P656
Wire holders		
P702	25051087	NSCT-3P874
P801	25051104	NSCT-10P891
P802	25051129	NSCT-13P916

DISPLAY CIRCUIT PC BOARD (NADIS-4977-3)

CIRCUIT NO.	PART NO.	DESCRIPTION
Q703	212130	BJ246GK,FL tube
D704	225290	SEL4110R,LED
S701-S719	25035652	NPS-111-S604,Switches
P701A	25050893	NSCT-29P688,Socket
	27190939Y	Holder FL

INPUT VOLUME PC BOARD (NAAF-4978-3)

CIRCUIT NO.	PART NO.	DESCRIPTION
R745	5104337Y	N09RL20KB15,Variable resistor
P702a	25051087	NSCT-3P874,Wire holder

**INPUT VOLUME PC BOARD****POWER SUPPLY PC BOARD (NAPS-4979-3)**

CIRCUIT NO.	PART NO.	DESCRIPTION
P901	25051109	NSCT-5P896,Wire holder
PW01	25055676	NPLG-2P632,Plug

NOTE: THE COMPONENTS IDENTIFIED BY MARK  ARE CRITICAL FOR RISK OF FIRE AND ELECTRIC SHOCK. REPLACE ONLY WITH PART NUMBER SPECIFIED.

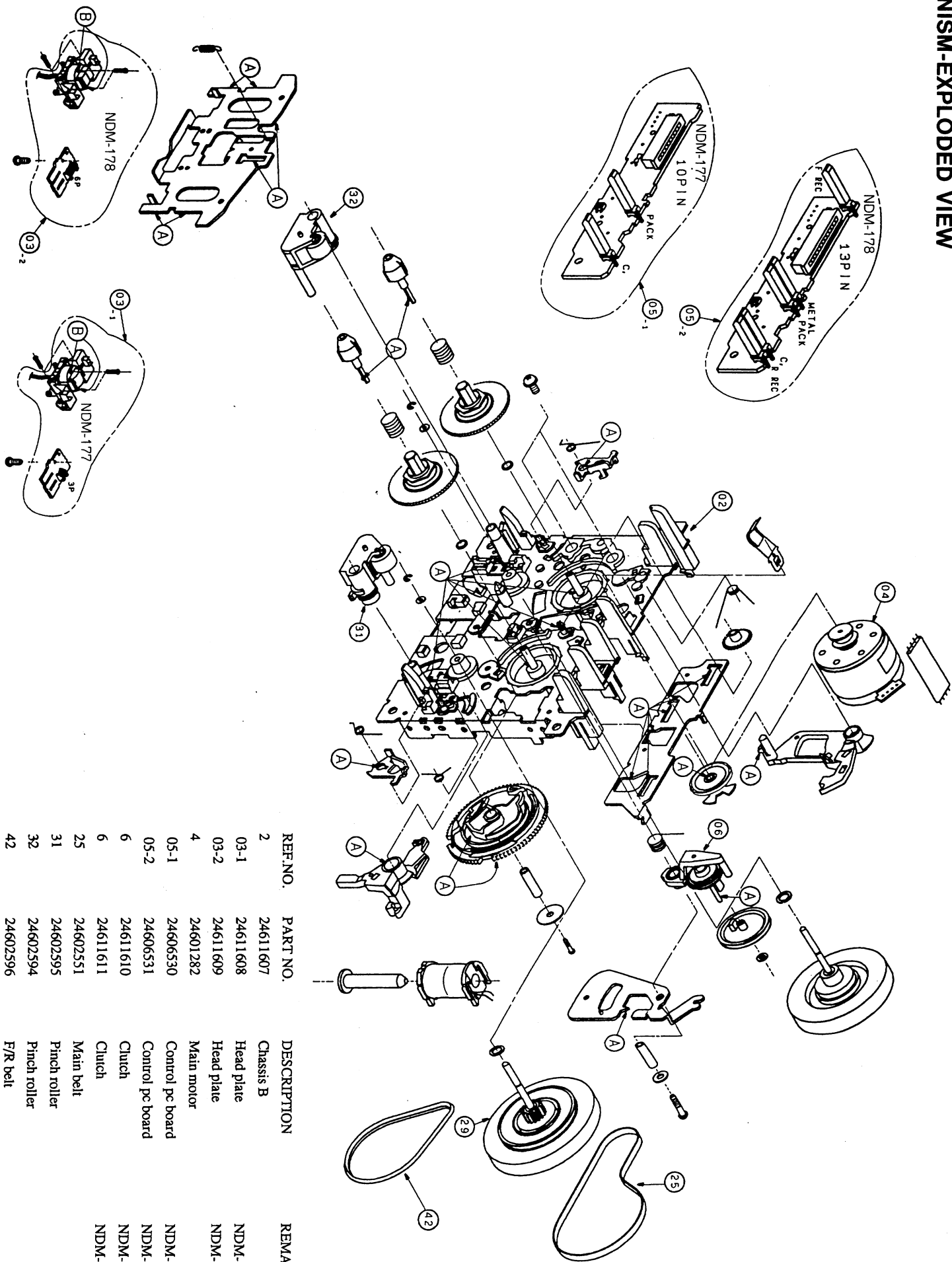

REF. NO.	PART NO.	DESCRIPTION	REMARKS
2	24611607	Chassis B	NDM-177
03-1	24611608	Head plate	NDM-177
03-2	24611609	Head plate	NDM-178
4	24601282	Main motor	
05-1	24606530	Control pc board	NDM-177
05-2	24606531	Control pc board	NDM-178
6	24611610	Clutch	NDM-177
6	24611611	Clutch	NDM-178
25	24602551	Main belt	
31	24602595	Pinch roller	
32	24602594	Pinch roller	
42	24602596	F/R belt	

PACKING VIEW

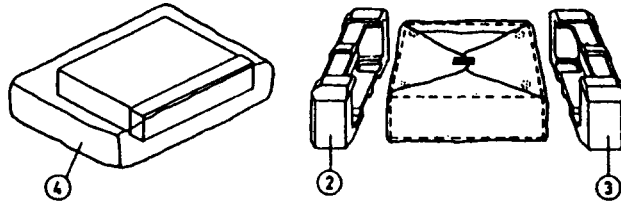

REF. NO.	PART NO.	DESCRIPTION
1	29052840Y	Carton box
2	29091637-1AY	Pad R
3	29091636-1AY	Pad L
4	29100034-1Y	650×850, Poly bag
	Accessory bag ass'y	
	2010244Y	Connection cord
	29342064Y	Instruction manual
	29365019B	Warranty card <N>
	29358002K	Service station list <N>
	29361784Y	Label UPC <N>
	29100097-1Y	320×250, Poly bag

NOTE: <N>:U.S.A. model only